



Installation and setting instructions

Gatelock Type VL31

Publication Number - II029/0401
Part Number: 002031-000002

Important

These instructions must remain with the product to ensure correct installation. If extra copies are required please contact Dewhurst plc and quote publication number and issue

If you have any problems or questions, please contact our technical support desk direct on **+44 (0)20 8607 7322/7383** during office hours.

Dewhurst plc

Inverness Road Hounslow TW3 3LT United Kingdom
tel +44 (0)20 8607 7300 fax +44 (0)20 8572 5986
info@dewhurst.co.uk www.dewhurst.co.uk

FIGURE 1

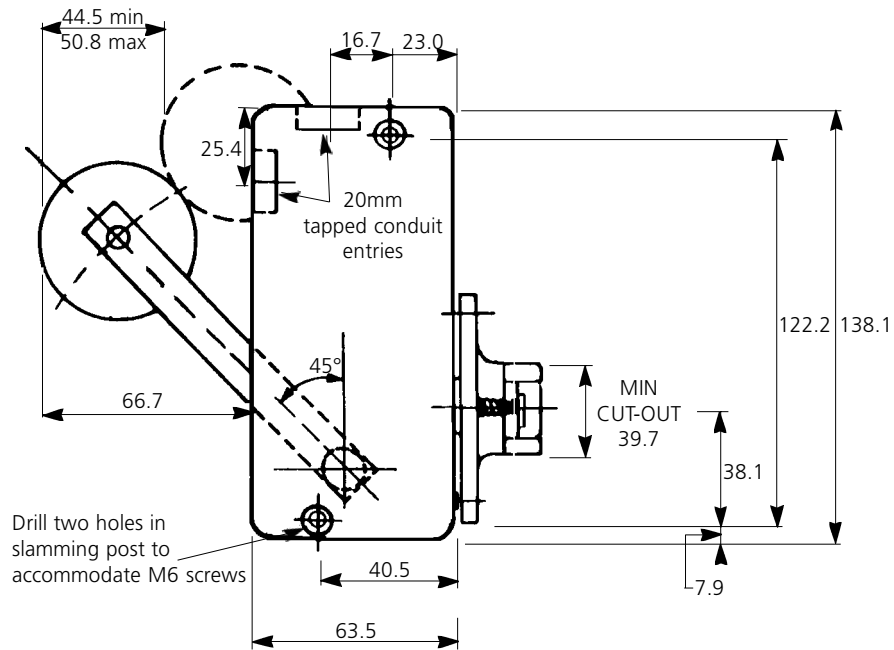

FIGURE 2

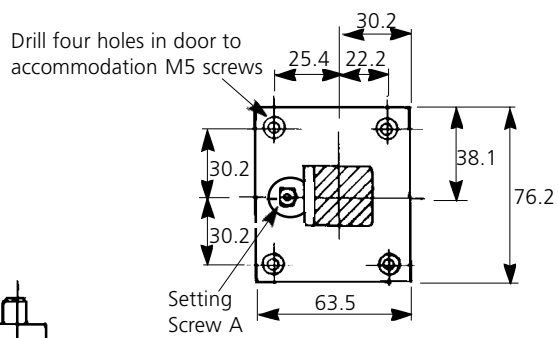
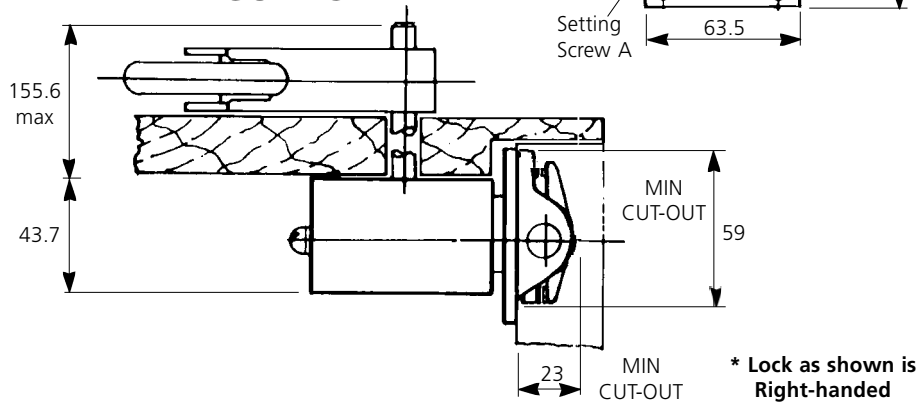

FIGURE 3



APPLICATION

The VL31 Gatelock is robustly constructed for installation on lift landings with single swing doors.

Operation is in accordance with BS5655 : Part 1 : 1986, except for Clause 7.7.3.1.1 and Appendix F.1.

For use as like-for-like replacement only, in accordance with BS5655 : Parts 11 & 12 : Clause 2.2.

ENVIRONMENT

VL31 is suitable for application in all normal indoor locations. Abnormal locations involving water spraying or splashing, chemical fumes and ignitable or explosive gases or dusts, require more detailed consideration. If in doubt concerning location or installation, consult the manufacturers.

OPERATION

The gatelock should be used in conjunction with a suitable retiring ramp. (Dewhurst Type FR21 is suitable for this application).

When the landing door is closed, the beak enters the lock and engages with an insulated cam which carries contacts that then complete a primary circuit (A). When the ramp clears the lock roller the operating arm of the gatelock falls forward allowing the locking plate to move downward, trapping the beak in position. The beak locking action is accompanied by the completion of a secondary circuit (B), but only if the primary circuit has been made.

MECHANICAL INSTALLATION

The gatelock must be installed with the beak and the operating arm below the lock centre line and with the conduit entries at the top. Check that the gatelock has been supplied to suit the handing required.

The gatelock must be mounted with the beak entry face in line with the slamming post, but not in front of it. Use dimensional data supplied to mark the fixing positions for the lock on the slamming post and drill holes to accommodate M6 screws. Drill a 15mm diameter hole through the slamming post, to accommodate the shaft. Loosen clamp nuts and remove operating arm from shaft. Pass shaft through aperture ensuring movement is unrestricted. Secure lock to the slamming post with two M6, rustproof, countersunk-head screws together with spring-washers and nuts. Now replace operating arm on protruding shaft, partially tightening clamp nuts.

Using dimensional data supplied, mark the fixing positions and the cut-out for the beak carrier on the swing door. Cut out door as required, see Figures 1, 2 and 3, allowing free movement of the beak on its pivot. Secure beak carrier to door using M5, rustproof, countersunk-head screws.

Check that the beak enters the lock smoothly, if not, adjust setting screw A to ensure that it does. Tighten all fixing screws and nuts, except clamp nuts.

Move the operating arm along the shaft until the roller centre line coincides with the centre line of the retiring ramp. Set the operating arm at 45° to the lock body, with the roller above the centre line and towards the lift.

Set the retiring ramp to move the roller a minimum of 44.5mm and a maximum of 50.8mm towards the lock body as illustrated. Tighten nuts on the clamp to compress fully the spring-washers but do not over-tighten.

If, when the operating arm is positioned on the shaft an excessive length remains beyond the arm, cut off surplus leaving between 6.3mm and 19.0mm of length.

ELECTRICAL CONNECTIONS

Ensure main and control supplies are isolated.

Remove front cover from the lock. Utilise one of two 20mm tapped conduit entries to bring wires into the gatelock. Ensure conduit termination is tight and secure. If flexible conduit is utilised, a separate earth wire must be installed in the conduit and must be securely connected to a suitable earth terminal in the electrical installation. Plug unused conduit entry.

Connect primary circuit using beak contact terminals A and secondary circuit using contact terminals B. Connect earth wire to terminals E. See Figure 4.

Check that the cables do not impede movements of the mechanism and that the springs controlling the locking plate are correctly located.

Replace front cover and tighten securing screws.

CONTACTS

Both sets of contacts are self-aligning and have a self-cleaning action with positive knock-off feature.

FIGURE 4

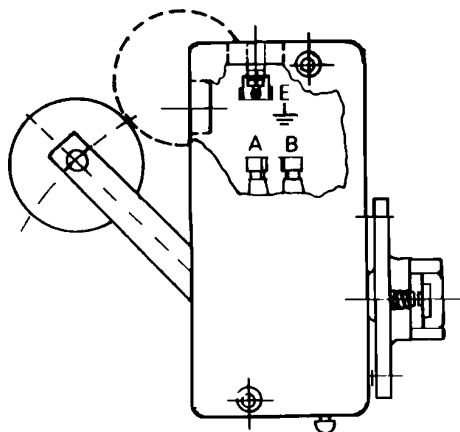

All dimensions in mm

NOTES:

1. Roller operating force 1kgf
2. No cantilever load to be applied to shaft
3. Lock will operate at a minimum radius of 381mm between centre of beak and centre of door hinge

